

ABLOY® DA461 SWING DOOR OPERATOR

– *Installation and commissioning manual*

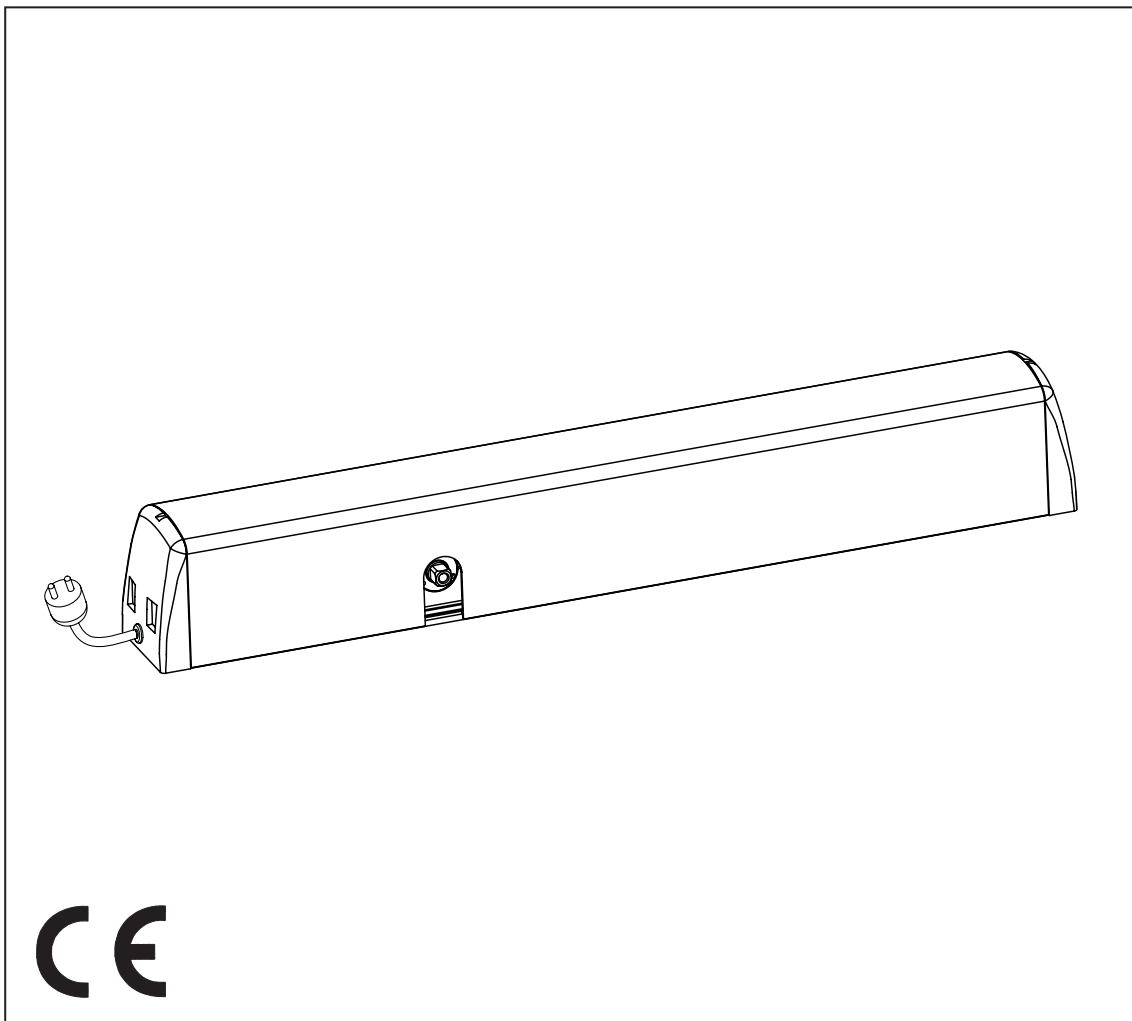

APPROVALS / STANDARDS

Electrical safety tested and approved FI, S, N, D (according to CB-scheme)

Low Voltage directive 2006/95/EC

EMC directive 2004/108/EC

Approvals in fire doors (Finland):

EN 13501-2

EN 1634-1



Warning!



Warning!

----- THIS MANUAL CONTAINS IMPORTANT SAFETY INSTRUCTIONS -----

Warning - IT IS IMPORTANT FOR SAFETY OF PERSONS TO FOLLOW THESE INSTRUCTIONS.

----- SAVE THESE INSTRUCTIONS -----

This appliance is not intended for use by persons (including children) with reduced physical, sensory or mental capabilities, or lack of experience and knowledge, unless they have been given supervision or instruction concerning use of the appliance by a person responsible for their safety.

Do not allow children to play with fixed controls.

Frequently examine the installation for imbalance and signs of wear or damage to cables, springs and mountings. Do not use if repair or adjustment is necessary.

Disconnect the supply when cleaning or other maintenance is being carried out.

Before installing the operator, check that the operator is in good mechanical condition and it opens and closes properly.

Ensure that entrapment between door and the surroundings is avoided.

Ensure that the operator is suited for installation. Check temperature, humidity, door weights, etc. restriction in line with specifications applicable in the manual or other Abloy® Oy material.

Note!

Instructions, design specifications and illustrations which are contained in this manual are not binding. Abloy Oy reserves the right as part of ongoing product development to make changes without previous notice.

CONTENTS

1	REVISION	4
2	CONTENT OF DELIVERY	5
3	GENERAL INFORMATION	6
4	OPERATION	7
5	MAIN SWITCH AND MODE SWITCH.....	7
6	DOOR WEIGHT	8
7	INSTALLATION.....	9
	7.1 Installing the mounting plate DA104	10
	7.2 Assembly of the operator and standard arm DA147, DA148 to the closing side	11
	7.3 Assembly of the operator and sliding arm DA149 to the closing side.....	12
	7.4 Assembly of the operator and sliding arm DA149 to the opening side	13
	7.5 Removing of the position sensor.....	14
	7.6 Door closer adjustments	14
8	INTERNAL CONNECTIONS	16
9	COMMISSIONING.....	17
10	A SAFE DOOR.....	19
11	EXTERNAL CONNECTIONS.....	20
12	CONNECTION EXAMPLES	21
	12.1 Safety sensors DA001 and DA002	21
	12.2 DA061 and DA062 Microwave motion sensor	22
	12.3 DA063 Microwave motion sensor	22
	12.4 DA033 Elbow switch	23
	12.5 DA039 ja DA049 rotary switch	23
	12.6 Electric locks EL402, EL404, EL502.....	24
	12.7 Motor locks EL490, EL590.....	24
	12.8 Motor locks EL420, EL520.....	25
	12.9 Electric lock EL410	25
	12.10 Fire door system	26
13	SELF DIAGNOSTICS.....	27
14	MAINTENANCE	28
	14.1 Adjusting the clearance of the electromagnetic clutch.....	29
15	SPARE PARTS	30

1 REVISION

Following pages have been revised:

Page	Revision
------	----------

As at 04.06.2008.

2 CONTENT OF DELIVERY

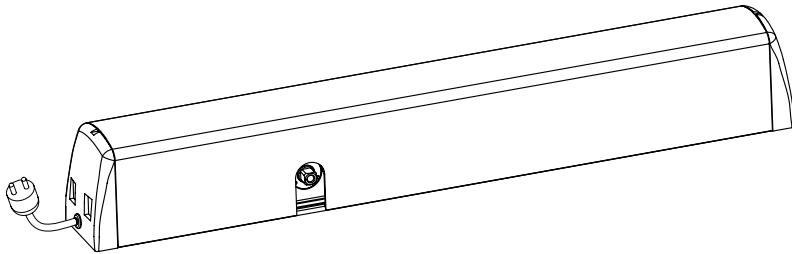

DA461 Swing door operator
- screws 6 pcs M6x14

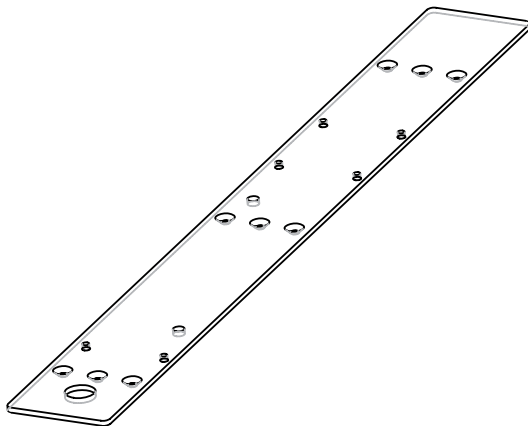

DA104 Mounting plate
- screws 6 pcs 5,5x32

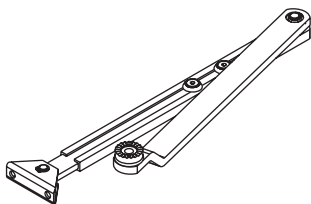

DA147 Standard arm
- screws 2 pcs 5,5x32
and 1 pcs M8x20 + M8x30

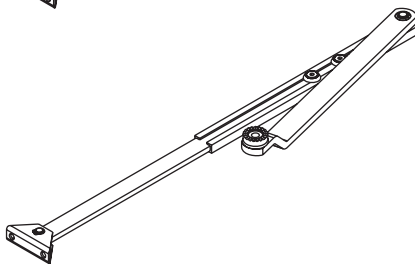

DA148 Extended arm
- screws 2 pcs 5,5x32
and 1 pcs M8x20 + M8x30

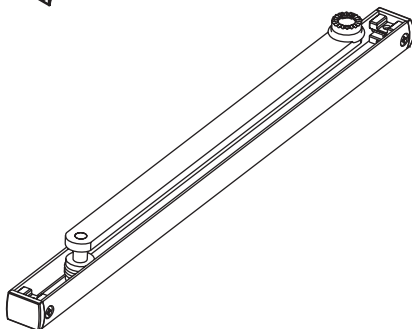

DA149 Sliding arm
- screws 2 pcs 5,5x50
and 1 pcs M8x20 + M8x30



DA150/01 Extension piece 10 mm
- M8x35

DA150/02 Extension piece 20 mm
- M8x35 + M8x45

3 GENERAL INFORMATION

Technical data

Measures

- 721 (L) x 85 (H) x 107 (W) mm
- Weight 9 kg
- Supply voltage 100/230 VAC ($\pm 10\%$) 50...60 Hz
- Rated output 120 W
- Enclosure class IP20

Temperature range

- Storage -20...50 °C (in dry premises)
- Operation -15...50 °C (in dry premises)
- The automatic swing door operator must not be installed in applications where it is subjected to water or snow

Interfaces

- Voltage output 24 VDC, stabilized, 500 mA (max 800 mA for 3 seconds)
- Potential free relay output
0,8 A @ 30VDC resistive load
0,3 A @ 30VDC inductive load

Door closer according EN1154:

<i>Class</i>	Standard arm	Sliding arm	Closing torque
	Door mass [kg] / width [mm]	Door mass [kg] / width [mm]	[Nm] (0-4°)
1		20 / 750	9
2		40 / 850	13
3	60 / 950	60 / 950	18
4	80 / 1100	80 / 1100	26
5	100 / 1250		37
6	120 / 1400		54

Features

- Easy to install
- Normal door closer function when the power is switched off or templed
- Push&Go as a standard feature
- Prepull before opening
- Adjustable hold open time 0...60 s or sequential use
- Fire detector connection
- Lock control relay with NO/NC contacts
- Secondary DC inlet for power back up (24 VDC ($\pm 15\%$), min. 5A)
- Maximum opening angles:
 - With standard arm 110°
 - With sliding arm (on the opening side) 100°
 - With sliding arm (on the closing side) 100°

4 OPERATION

The Abloy® DA461 electromechanical swing door operator is especially suited to external and fire resisting doors.

The door is opened by motor force, and closed with the on board door closer. The motor and door closer are connected via clutch mechanism, which is engaged during the opening cycle, and released for the closing cycle.

If the opening cycle of the door operator is interrupted, the clutch mechanism will disengage, the Abloy® DA461 will try to open the door four times, stopping for one second before each attempt. After fourth attempt the clutch will release, and the door will close via the on board door closer.

The Abloy door operator is controlled with normally open devices, triggering closed. In the event of power failure the door operator reverts to manual opening, closing via the on board door closer making the product an ideal specification for Fire Resisting door sets. When the Abloy® DA461 is used on Fire Resisting door sets the unit must be interfaced with the Fire Detection system, ensuring that the door closes, in line with current European and local standards. [Local standards may vary due to local requirements, and the Installer must ensure that these have been adhered to]. The door operator will allow for manual escape, [and re closing] even after activation of the Fire Detection system.

The Abloy® DA461 has a "Push&Go" function. When Push&Go is in operation and door is pushed or pulled manually, operator opens the door to adjusted opening angle and closes the door after a 5 second of hold open time.

5 MAIN SWITCH AND MODE SWITCH

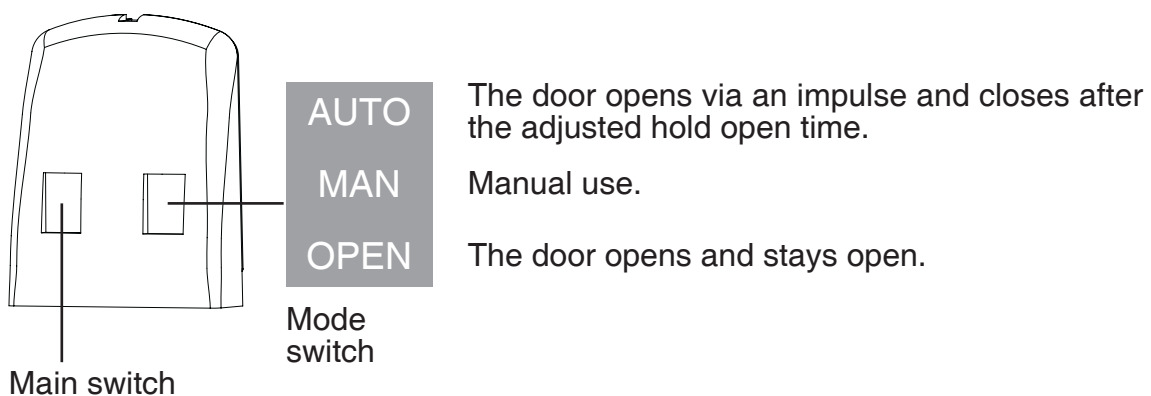

When the power is switched on, the mains switch lights up.

1 = on
0 = off

Note! There is 3 seconds constant delay when mode switch is changed position OPEN to AUTO or MANUAL.

6 DOOR WEIGHT

Standard arm

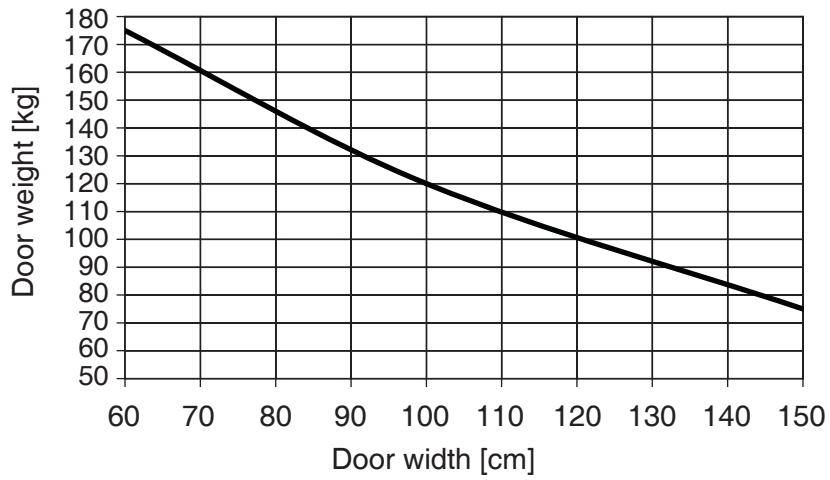
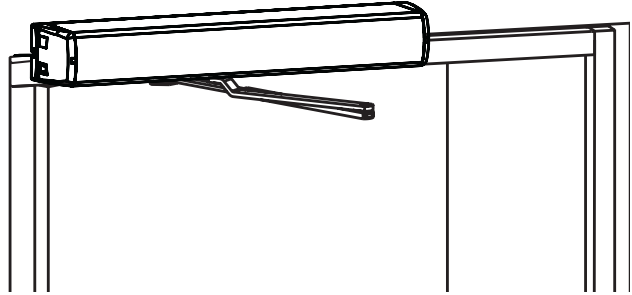

Sliding arm

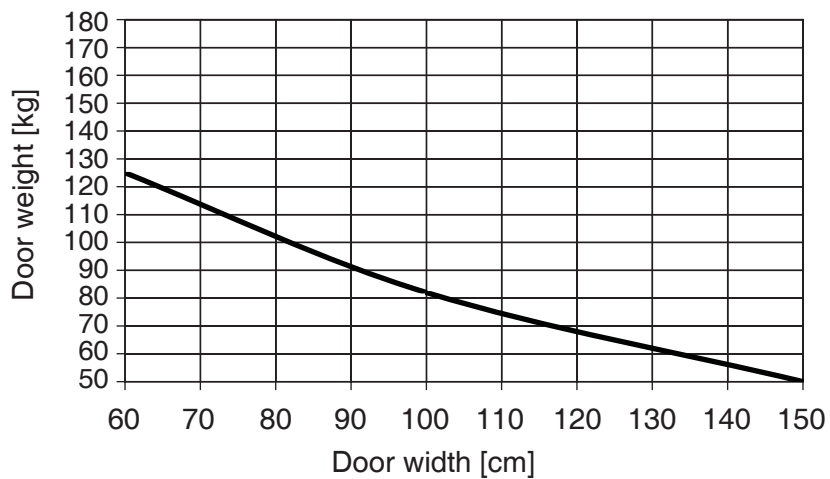
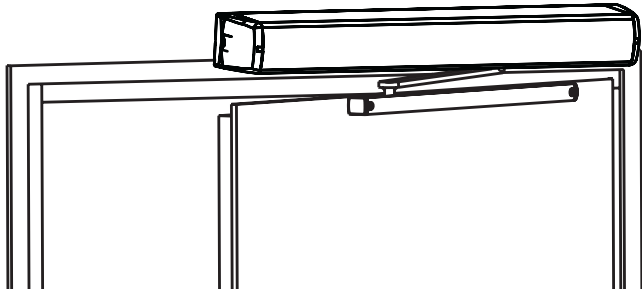

7 INSTALLATION

Tools required

- Drill
- Set of ball ended allen wrenches
- # 2 Phillips head screwdriver
- Flat blade screwdrivers, 2 pcs

Steps of installation

- Preparing installation
- Installing the mounting plate
- Mounting the operator and the arm
- Connecting the operator to mains
- Commissioning
- Testing
- Connecting impulse devices

Preparing installation

- Check the correct function of the door
 - Hinges
 - Door clearance
- Check the correct function of the lock
 - Lock case
 - Striker plate
 - Suitability of the lock's function

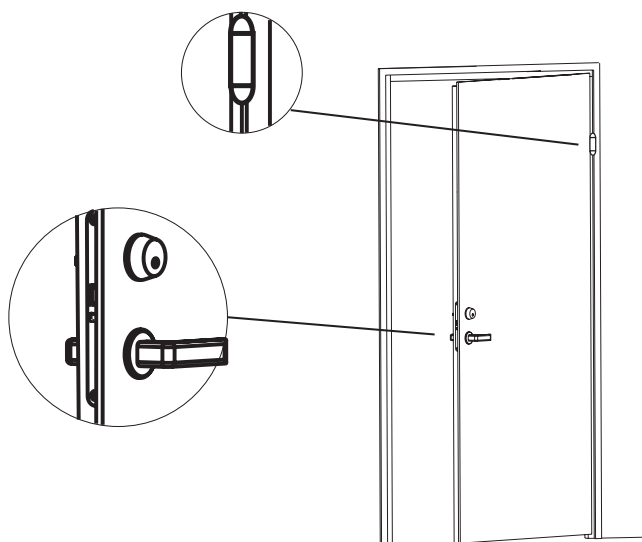

Removal of housing

Note! Remove the protective earth wire from cover and connect it back after installation.

Ensure the mains disconnected when removing or re-fitting the cover.

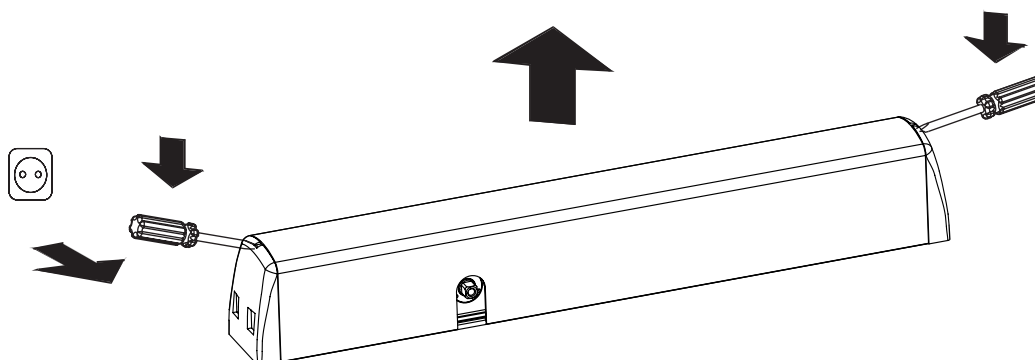

7.1 Installing the mounting plate DA104

The operator is installed on the transom, with the main switch located towards the hinge side of the door.

Use the mounting plate DA104 with the door operator ensuring the installation base is level. Securely fix the mounting plate to the transom.

Minimum requirement for wall profile is 5 mm (steel).

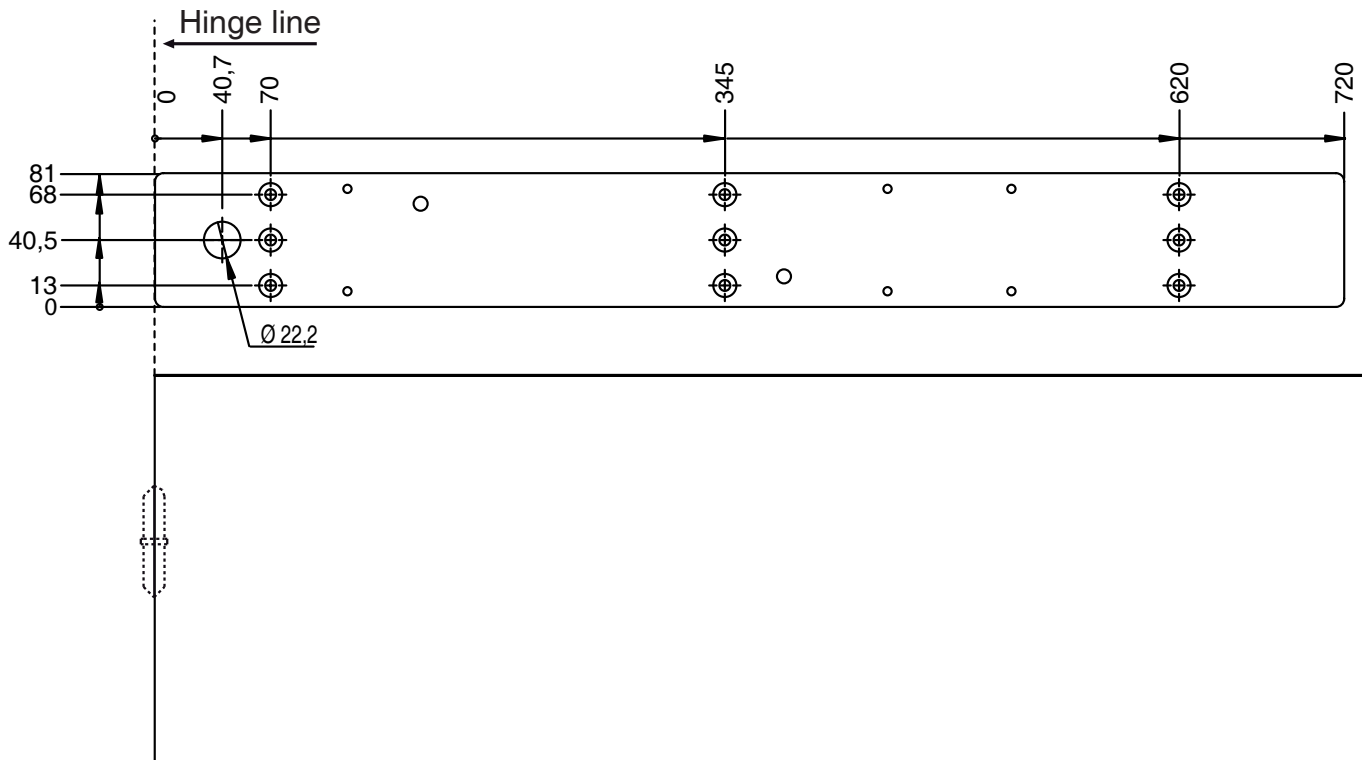

7.2 Assembly of the operator and standard arm DA147, DA148 to the closing side

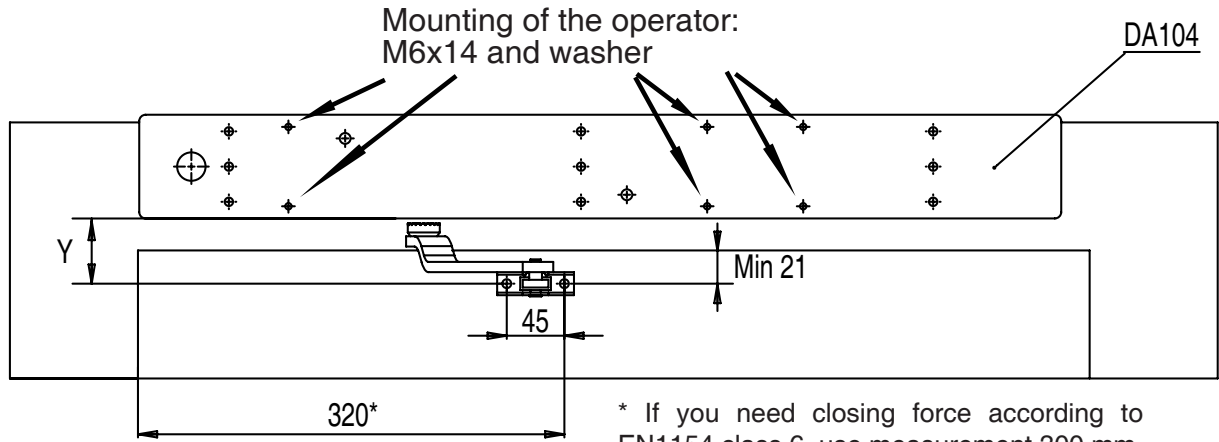

* If you need closing force according to EN1154 class 6, use measurement 300 mm.

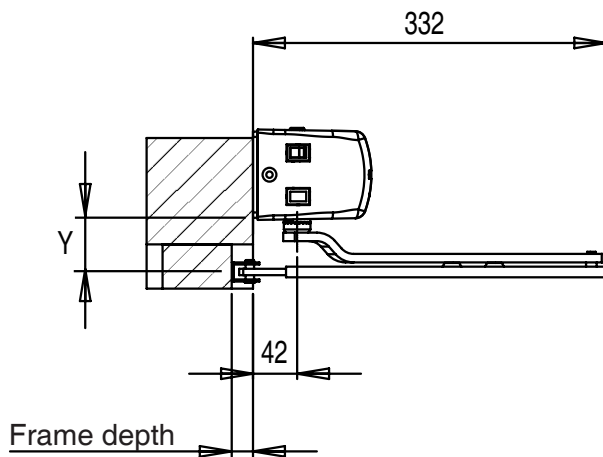

Y	Length of extension piece	Mounting of the arm
51	no extension piece	M8x20 + washer
61	10 mm (DA150/01)	M8x30 + washer
71	20 mm (DA150/02)	M8x35 + washer

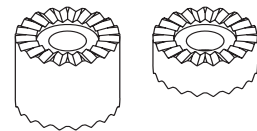

Pre-setting of the spring force

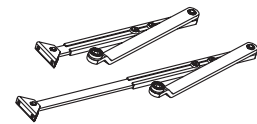
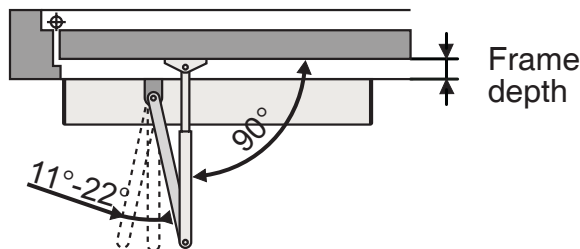

DA147 Frame depth 0-150 mm
DA148 Frame depth 150-250 mm

- After installation, ensure that the arm and door are properly adjusted.
- Mount a door stop to the door open position so that wind will not drive the door against the wall, resulting in damage.
- **Tighten the holding screw.**

7.3 Assembly of the operator and sliding arm DA149 to the closing side

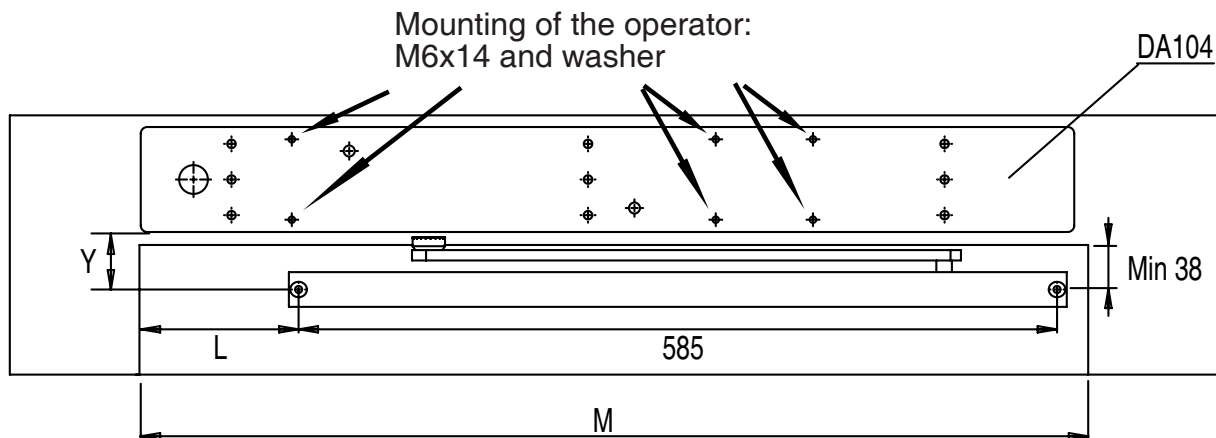

Frame depth	Arm distance L/mm	Minimum door width M/mm
< 50	120	740
50-100	50	670

Y	Length of extension piece	Mounting of the arm
48	no extension piece	M8x20 + washer
58	10 mm (DA150/01)	M8x30 + washer
68	20 mm (DA150/02)	M8x35 + washer

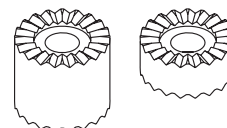
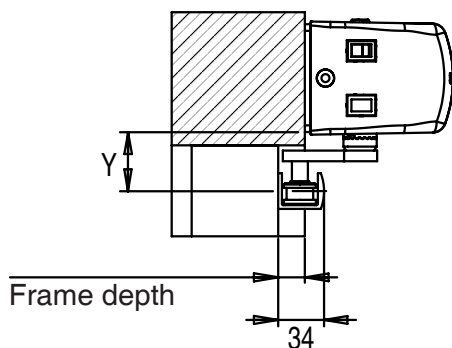

Pre-setting of the spring force

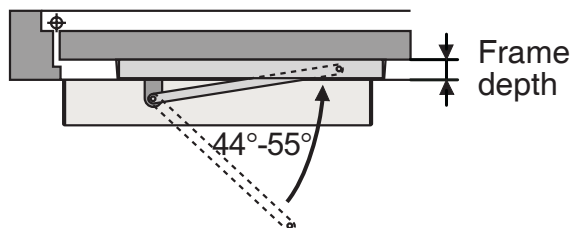

- After installation, ensure that the arm and door are properly adjusted.
- Mount a door stop to the door open position so that wind will not drive the door against the wall, resulting in damage.
- **Tighten the holding screw.**

7.4 Assembly of the operator and sliding arm DA149 to the opening side

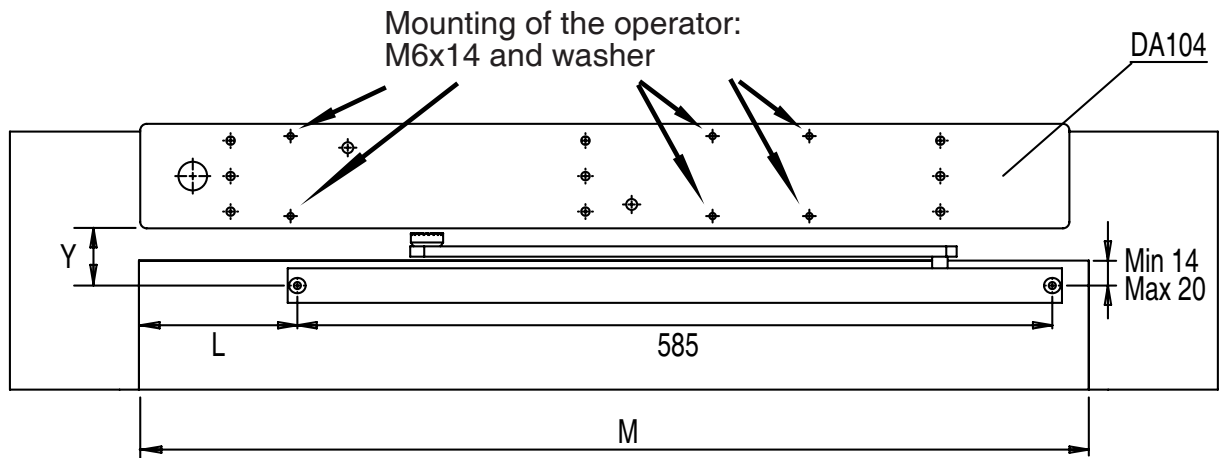

Frame depth	Arm distance L/mm	Minimum door width M/mm
< 100	90	700
100-200	170	800

Y	Length of extension piece	Mounting of the arm
44	no extension piece	M8x20 + washer
54	10 mm (DA150/01)	M8x30 + washer
64	20 mm (DA150/02)	M8x35 + washer

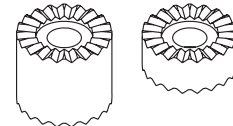
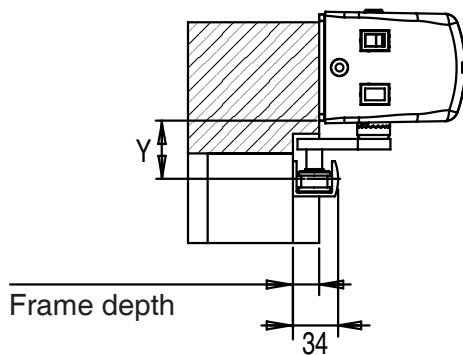

Pre-setting of the spring force

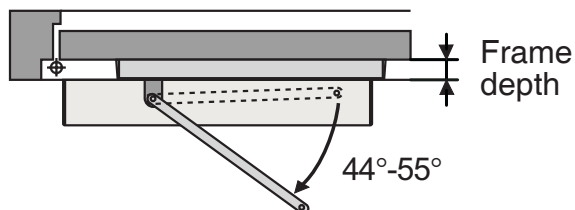

1. Mount the arm to the operator
2. Teach door open position 44°-55° (see page 18)
3. Remove the arm
4. Turn mode switch to OPEN
5. Close the door and mount the arm to the operator and to the sliding rail
6. Teach door closed and open positions again

- After installation, ensure that the arm and door are properly adjusted.
- Mount a door stop to the door open position so that wind will not drive the door against the wall, resulting in damage.
- **Tighten the holding screw.**

7.5 Removing of the position sensor

The position sensor must be removed, if the clutch or closing force need adjustment. This prevents possible damage of the sensor during adjustment.

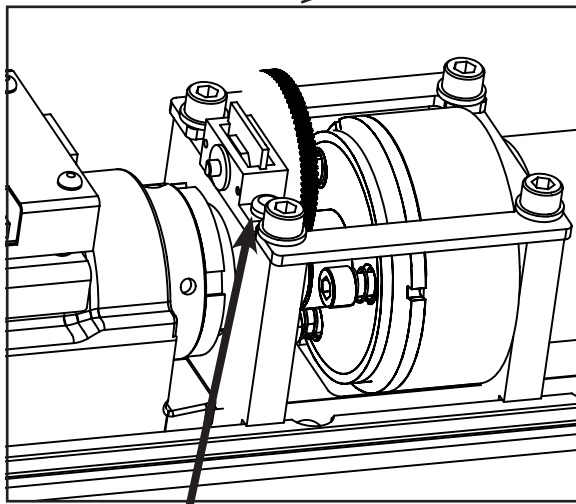
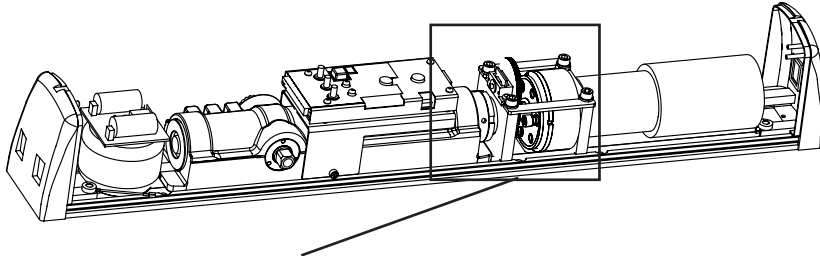

Fixing screw for position sensor

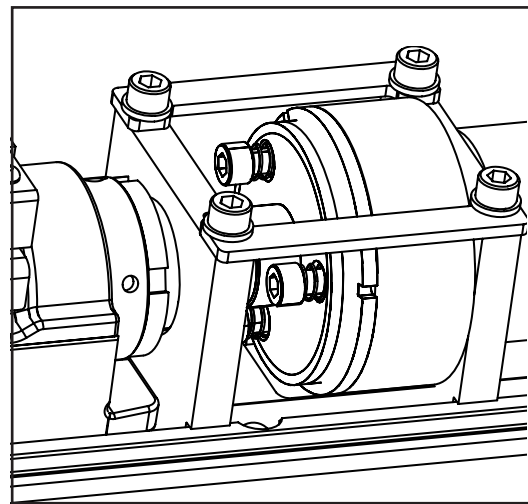

Position sensor removed

7.6 Door closer adjustments

Closing speeds

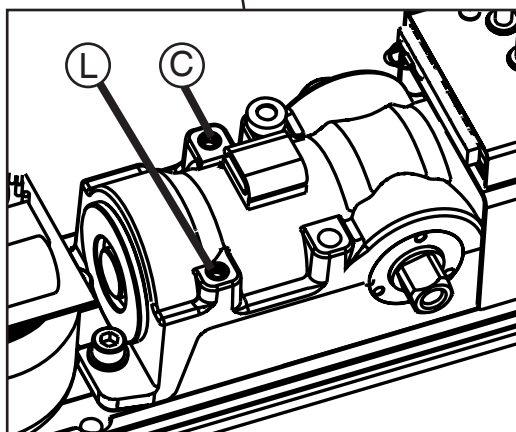
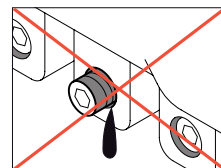
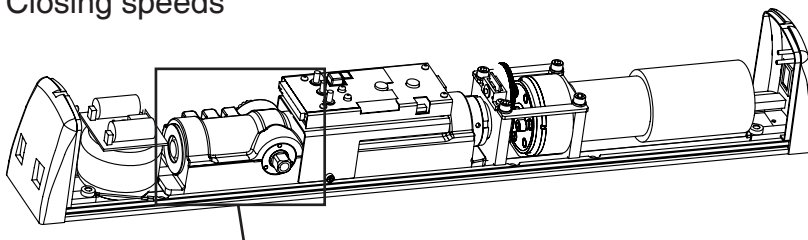

Ⓒ Closing speed Ⓓ Latching speed

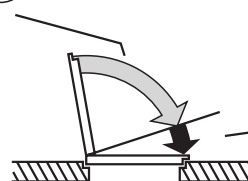

Closing force adjustment

Open the door fully and observe the closing function assuming that the door closes as is required, check the closing function from approximately 15° from the door's closed position ensuring that there is sufficient power to close the door fully.

Before adjusting the force of the door closer it is sensible to try and obtain a satisfactory closing action utilising the closing and latching speed. If this can not be achieved adjust the door closer force as shown.

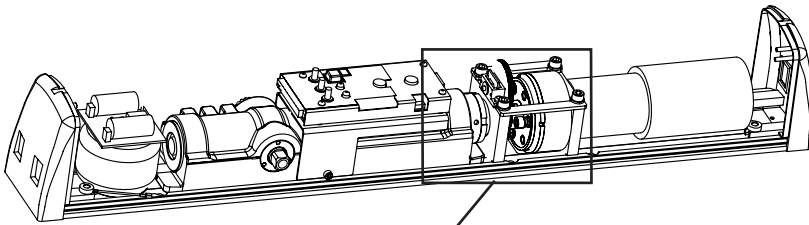

Fastener screws

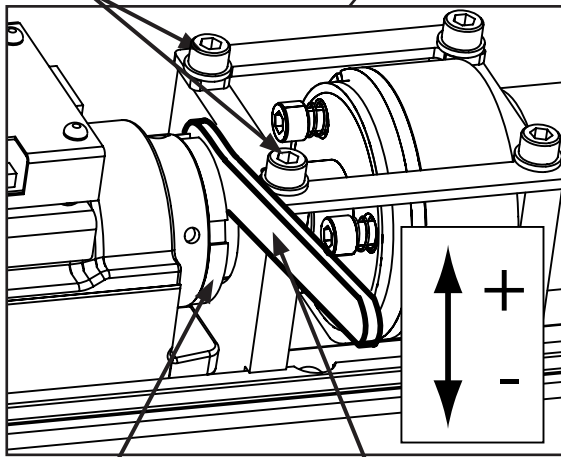

Lock nut

Spanner wrench

Force increases in "+" direction

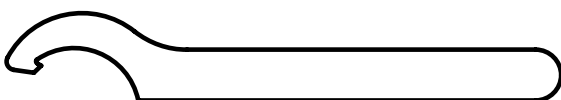

Spanner wrench

- Before adjusting closing force, remove position sensor (see 7.5). Make sure operator's cables are not damaged during adjustment.
- Loosen lock nut before adjusting closing force.
- Use spanner wrench for force adjustment (included in delivery). Loosen the fastener screws a little if needed.
- Tighten lock nut and fastener screws after adjusting.
- Factory setting for closing force is
Standard arm: EN4
- Adjustable between EN3-6
Sliding arm: EN2
- Adjustable between EN1-4
- Note - Fire Resisting door set require a minimum setting of level 3.

8 INTERNAL CONNECTIONS



- Electrical connections should be made by a qualified electrician.
- The power plug must have an easy access.
- If permanent connection is made unit must be equipped with an external switch providing all pole disconnection.
- Keep the mains disconnected during installation.

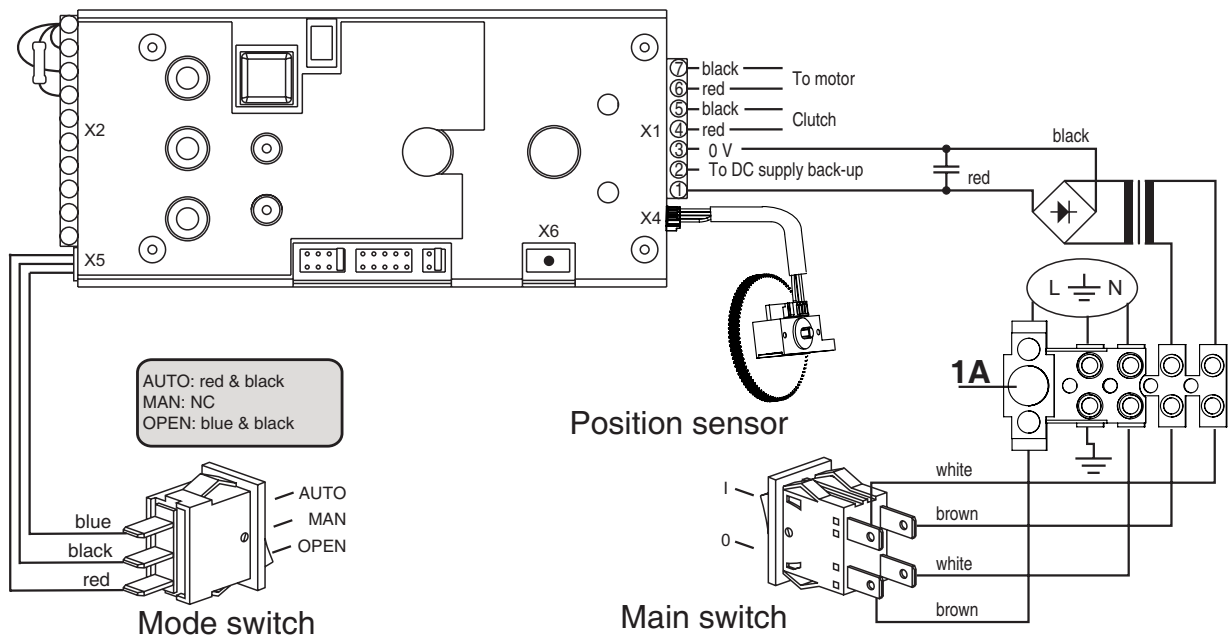



DC supply back-up

When not mains operated, or for back-up supply, the external 24VDC ($\pm 15\%$) supply (min 5A) can be connected to X1 connectors 2 and 3. Connect + from DC supply back-up to X1 connector 2 and GND to connector 3. No battery charging or maintenance is provided by DA461.



Local regulation vary with respect to electrical installations, and the installer must ensure that they are not in conflict with the locally applicable requirements.

9 COMMISSIONING

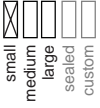
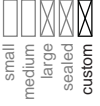
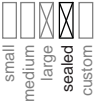
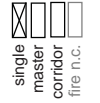
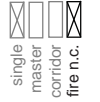
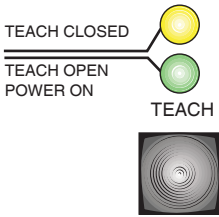
1 Check the free movement of the door.	
2 Turn mode switch to MAN.	The mode switch is located in the head panel.
3 Plug in the mains and turn the switch on. The main switch is located in the head panel.	
4 Choose the type of the arm.	 <p>Jumpers are located on the control board.</p> <p> Jumper is connected.</p> <p> Jumper is disconnected.</p>
5 Choose the size of the door.	
 <p>DOOR</p>	<p>S, M and L settings define door weight in ratio to door width. Always select at first S in to guarantee maximum safety. If there is not enough force on the operator for moving the door then shift setting from S to M. If the door behaviour is satisfactory then the chosen value is right. If not then shift to next setting point L.</p>
 <p>DOOR</p>	<p>Jumper in block "Custom" together with S, M or L gives you more power.</p> <p>S + Custom, force between S and M.</p> <p>M + Custom, force between M and L.</p> <p>L + Custom, force more than L.</p>
 <p>DOOR</p>	<p>"Sealed" enables motorised closing pull before opening. Select this to ensure the proper function of the lock when prepull is needed. Motorised closing will be activated 20-40 mm before the doors closed position.</p>
6 Check the OPTION.	
 <p>OPTION</p>	<p>Select "single" for a stand alone door. "Master" and "Corridor", not yet available.</p>
 <p>OPTION</p>	<p>If the jumper is connected then operator requires N.C. output from the fire detector.</p> <p>If the jumper is disconnected then operator requires N.O. output from the fire detector.</p>
7 Teach door open and closed position.	
	<ul style="list-style-type: none"> - Push TEACH-button to enter learning mode. - Teach the door closed position: Yellow led blinks: close the door and push TEACH-button. - Teach the door open position: Green led blinks: open the door to the desired angle and push TEACH-button. - Yellow "TEACH CLOSED" led blinks: close the door manually.

8 Opening speed and hold open time



Adjust the opening speed.

A slow door is a safe door. The door speed should be set to allow unhindered access but as slow as is possible.

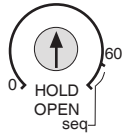

Adjust the hold open time (0...60 s).

Full right position (seq) means that every other impulse either opens or closes the door.

Time (sec)	Door weight (kg)				
	60	80	100	120	
Door width (mm)	800	2,7	3,2	3,5	3,9
	1000	3,4	4,0	4,4	4,8
	1200	4,1	4,7	5,3	5,8
	1300	4,5	5,1	5,8	6,3

Minimum safe opening and closing times for door of various widths and weights are summarized in the table.

9 Push&Go

In fully left position Push&Go is set to off.



In fully right position Push&Go function is on. Operator opens the door to adjusted opening angle and closes the door after a 5 second of hold open time.

Push&Go is functional only when the door is closed. Pushing on a door during its closing cycle will not activate the Push&Go feature. Push&Go only functions from the closed position.

10 Test the operation

Note! Long hold open time increases the safety of the door.

- Turn mode switch to AUTO.
- Test the operation.
- The door will open to the adjusted opening angle after five openings.
- If the function is not as desired, turn mode switch to MAN and repeat steps 4...10.
- If doors opening speed or jumper are changed, the door will open to adjusted opening angle after five openings.

10 A SAFE DOOR

The safety of an Automatic door is achieved with careful basic adjustments.

Low speed, higher speeds increase the force applied to any obstruction. The speed should be set so that users are able to pass through the door unhindered, with the speed set as slow is as reasonable possible. The position of the input devices are also a factor i.e. where ever possible, they should see users approaching and start to open allowing the door to open slowly.

The door operator should always be set to the lowest possible force setting, ensuring that the door operates smoothly, but equally does not have excessive force for the application.

In all cases the door size should be set to the smallest possible setting, S small, M Medium, L Large, remembering the half steps achievable with the custom setting we effectively have S, S+, M, M+, L, L+. We should always remember that these force setting also has an effect with the inbuilt safety settings, i.e. the more force applied, the lower the sensitivity, hence should the door make contact with an obstruction it will apply a greater force is the door weight is set higher.

We recommend that safety sensors are fitted to all applications, particularly on the driven side, opening face in the case of a DA461.

Higher speeds are only achievable when full safety is specified.

11 EXTERNAL CONNECTIONS

Connector X2

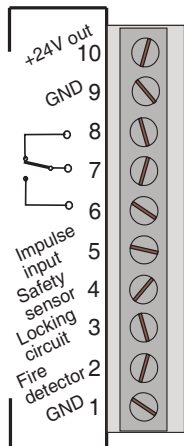

10	+24 VDC, 500mA output
9	Ground
6,7,8	Potential free relay output for lock drive
5	Impulse input
4	Safety sensor Ground to stop the door movement during operation
3	Locking circuit Inhibits the opening if the lock bolt is thrown. Grounding this input allows for opening
2	Fire detector
1	0 V

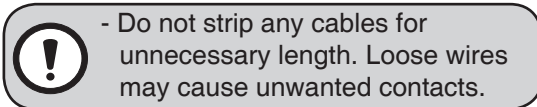

Fire detector:

Remove the LINK, between terminals 1 & 2, and connect the detection outputs, inputs.

During activation of the Fire Detection System the door will close via the on board door closer. Once the Fire Detection System, is deactivated, the door requires re-setting with a manual opening.

When the Abloy® DA461 is fitted to a Fire Resisting door set, the door operator MUST be interfaced with the Fire Detection system. Local requirements will vary, but the door must close in the event of activation in line with current European regulations. The Installer must ensure that the configuration meets the local prevailing regulations.

Safety sensor:

On the opening side of the door:

The Safety Sensor is connected to terminals 1 and 4, with the power taken from terminal 10, and grounded via terminal 9. The loop must have a 1K resistor in parallel across the terminals 1 and 4, [supplied]. This MUST be fitted in the safety sensor, in order that the door operator monitors the condition of the cable between the sensor and the operator. This cable is vulnerable due to the doors movement, and in the event of an open circuit it will prevent a potentially unsafe door opening.

The safety sensor is active, for the first 70% of the door opening, it will not stop the door opening when it has passed the 70% point, because it has been designed so that it can ignore any obstacles, like the door reveal, or walls running in parallel to the door opening angle.

The resistor between terminals 1 and 4 must be left in position if a safety sensor is not used.

On the closing side of the door:

Safety sensor is connected to impulse input terminal 5. When safety sensor detects an obstacle , it reopens the door.

Impulse input:

The closing contact drive (NO) must be potential free. The impulse device must be installed within direct sight of the door. Maximum length of the impulse device cable is 30 m. The total resistance of the control switch and its wiring must not exceed 100 ohm, when switch is closed.

12 CONNECTION EXAMPLES

12.1 Safety sensors DA001 and DA002

On the opening side

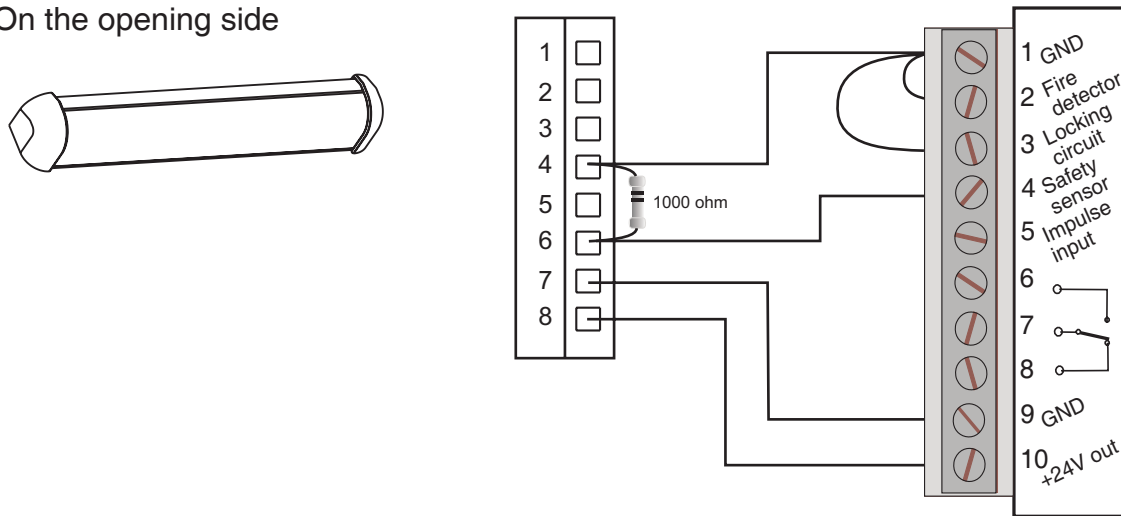

The loop must have a 1K resistor in parallel across the terminals 1 and 4. This must be fitted in safety sensor, in order that the door operator monitors the condition of the cable between the sensor and the operator. This cable is vulnerable due to the door's movement, and in the event of an open circuit it will prevent a potentially unsafe door opening.

When sensor detects an obstacle, the operator stops the door.

On the closing side

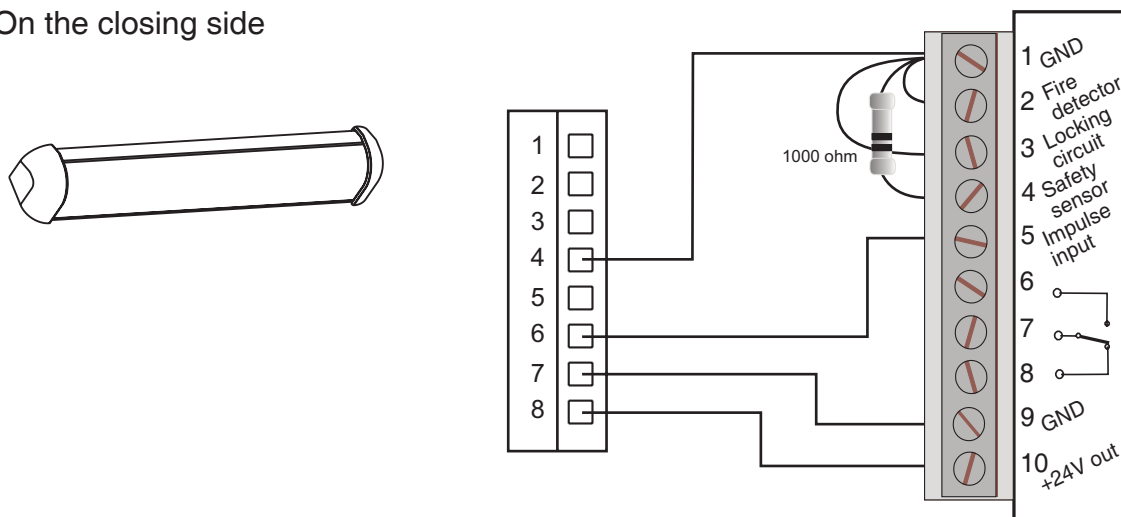

When sensor detects an obstacle, the operator opens the door for duration of the hold open time.

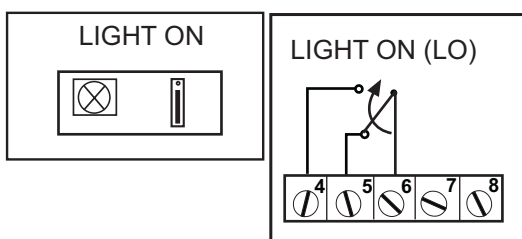

Jumper settings and connection block for DA001 and DA002.

12.2 DA061 and DA062 Microwave motion sensor

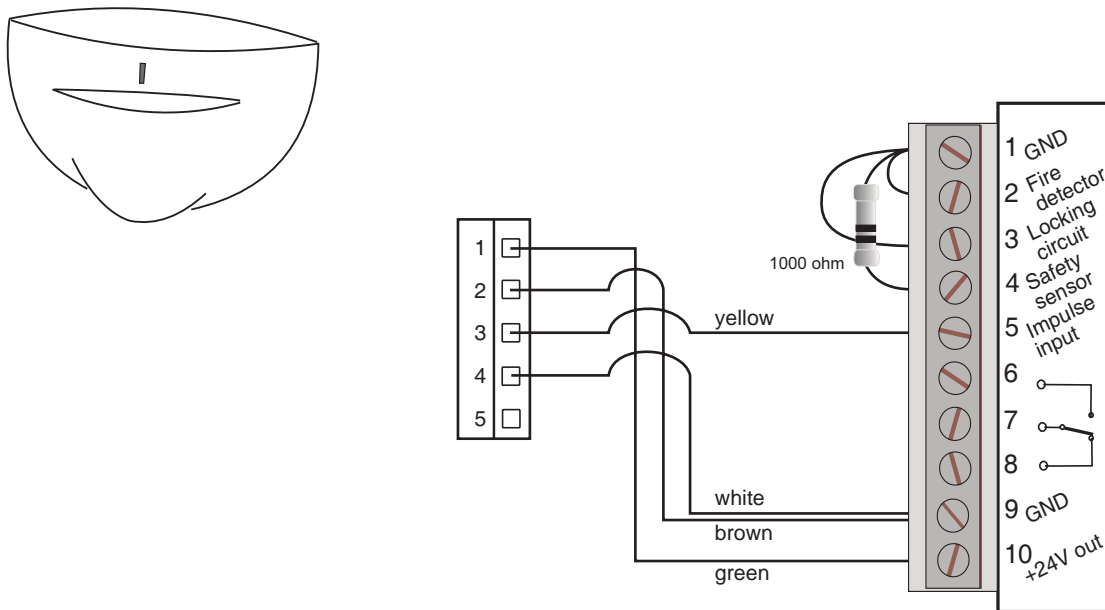

12.3 DA063 Microwave motion sensor

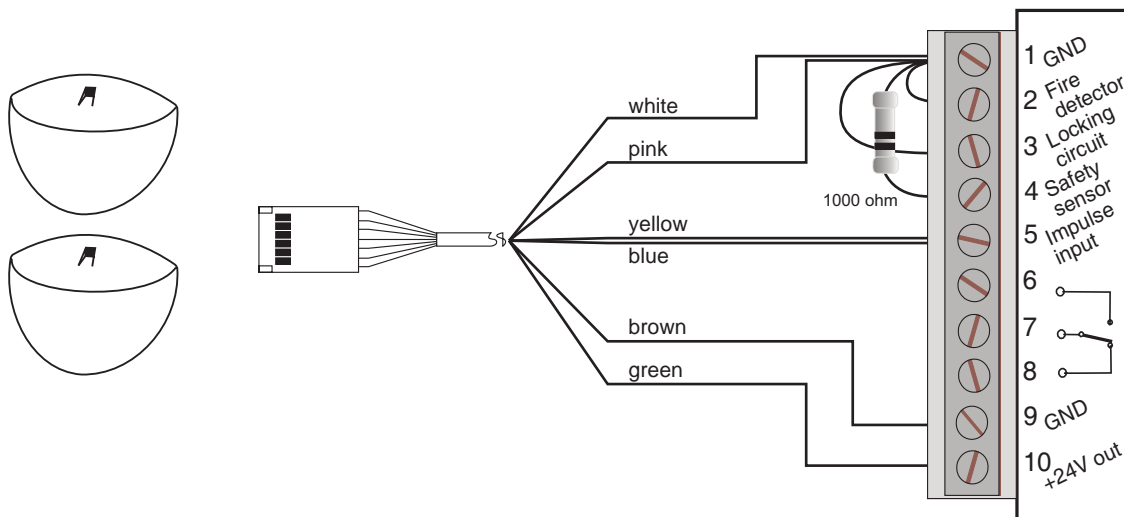

12.4 DA033 Elbow switch

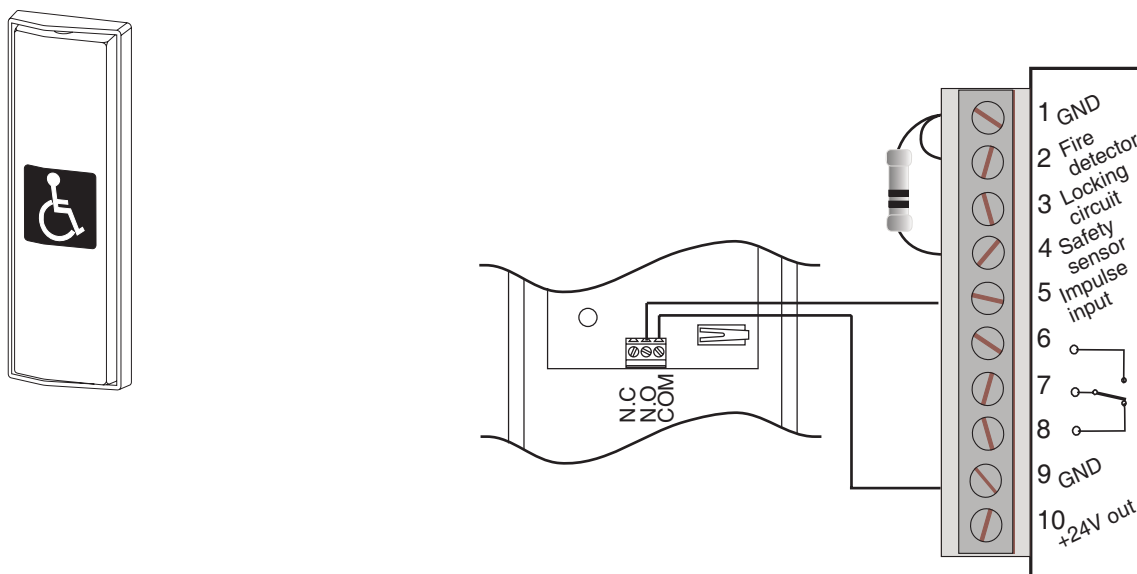

12.5 DA039 ja DA049 rotary switch

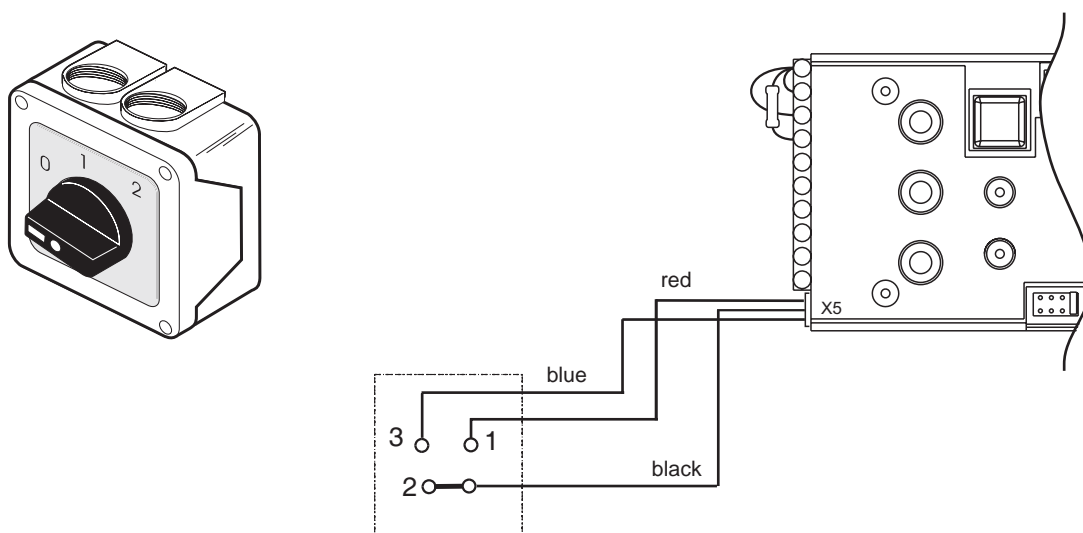

12.6 Electric locks EL402, EL404, EL502

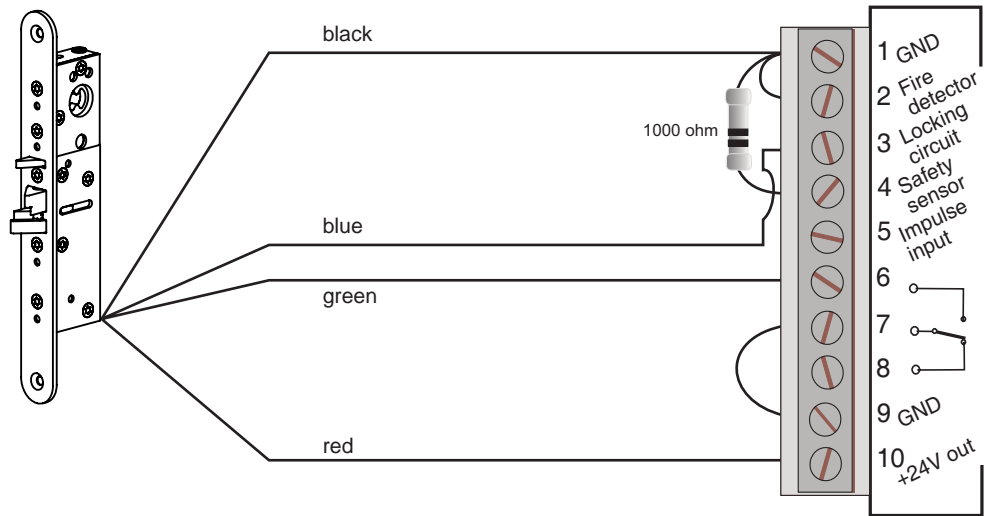

NOTE! Not to be installed in doors with seal force. Bolt and trigger bolt have to be lubricated when lock is installed and when necessary.

12.7 Motor locks EL490, EL590

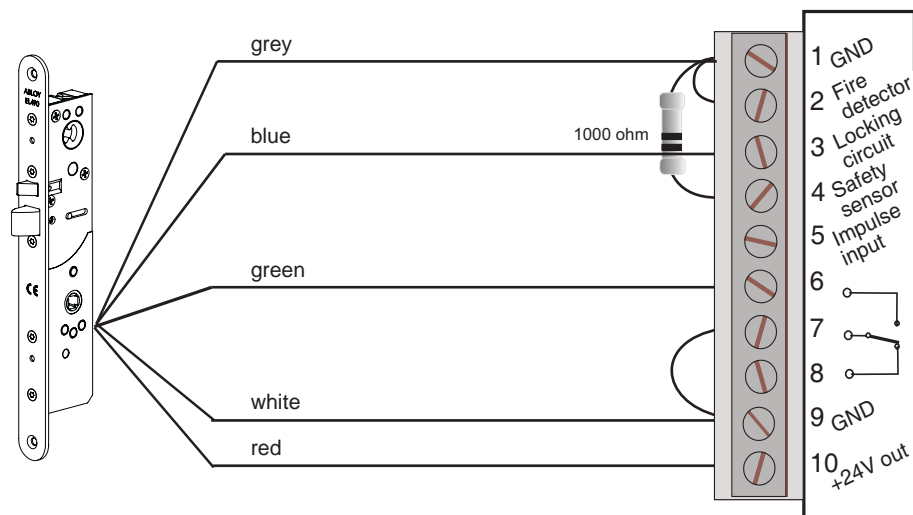

12.8 Motor locks EL420, EL520

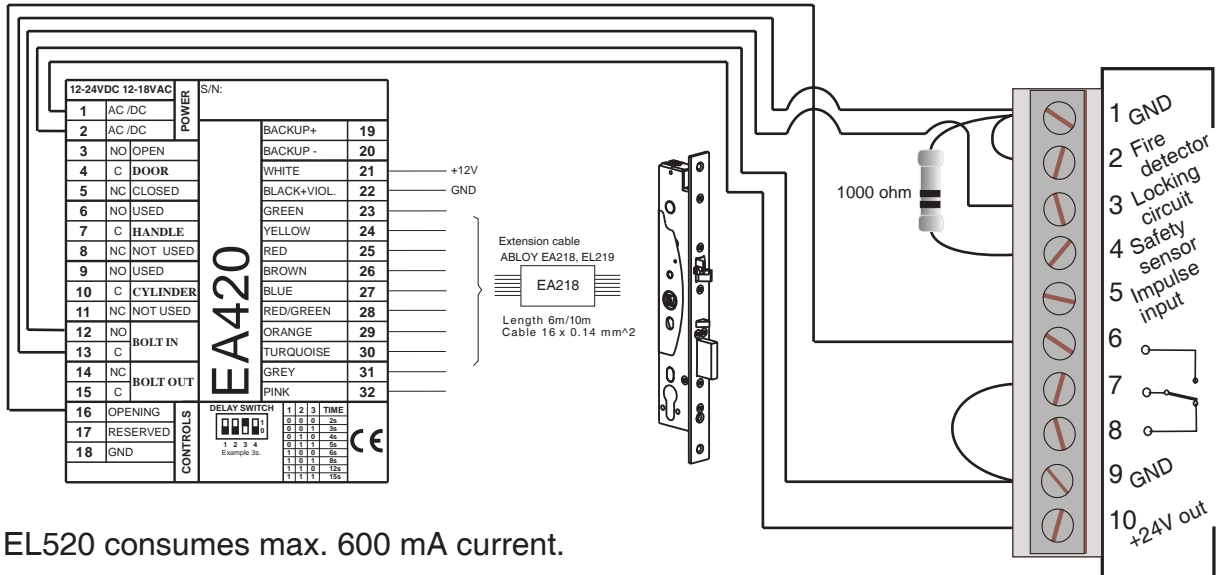

EL520 consumes max. 600 mA current.

12.9 Electric lock EL410

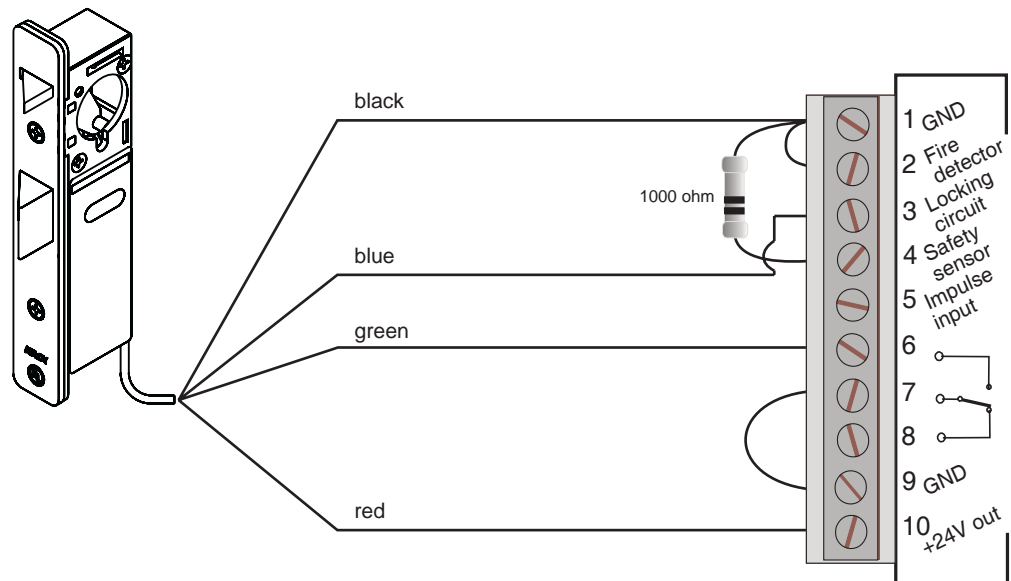

12.10 Fire door system

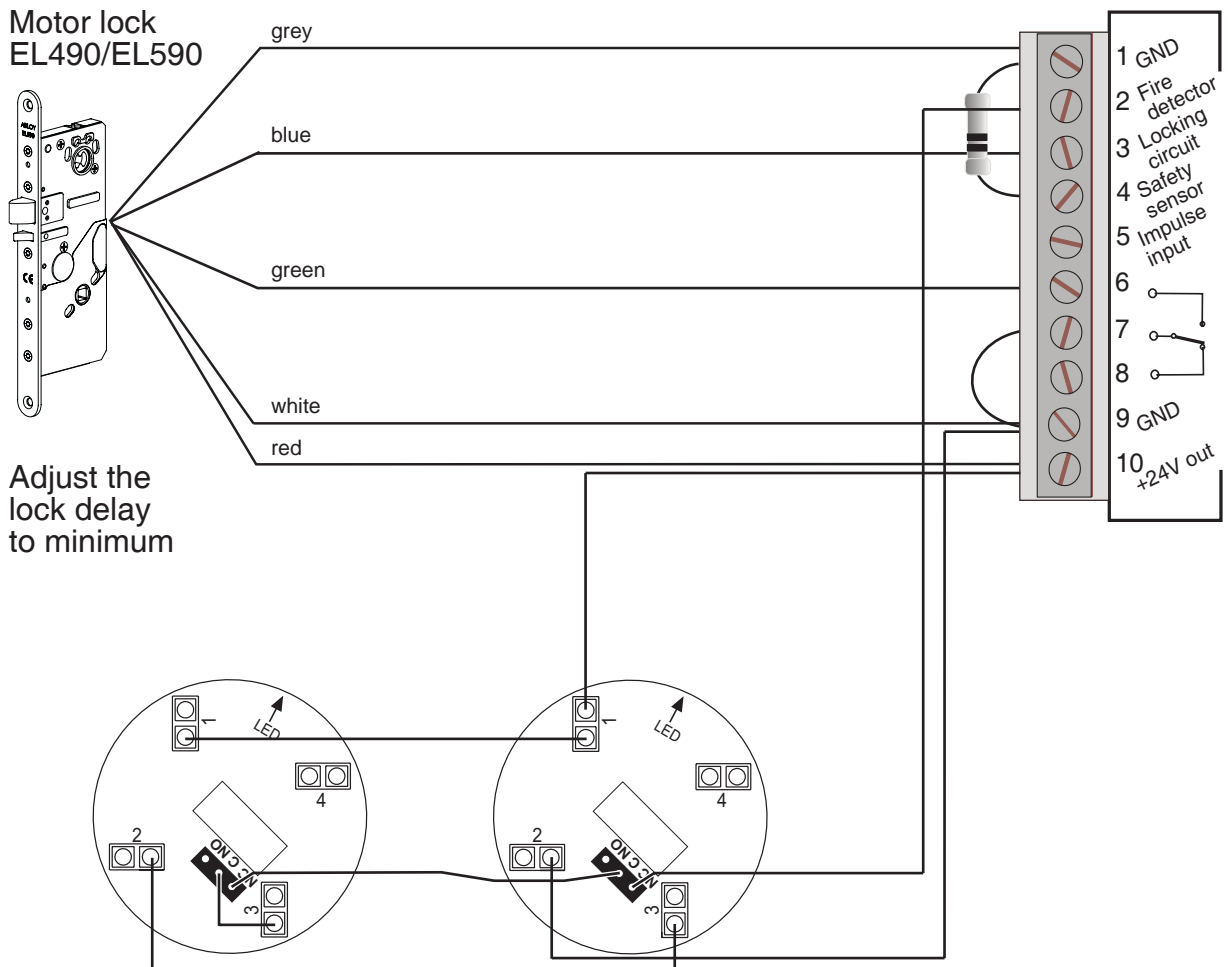

OPERATION:

When the fire detection system reacts, it's relay switches on. Then the GND (-) is disconnected from the operator's control unit (connector 2). The operator doesn't open the door from impulse but it can be opened manually. The door closer of the operator closes the door after manual opening.

Detection activation	->	The door closes
Power failure	->	The door closes by spring

After detection activation, one manual opening is required to re-energise the operator to chosen program selector mode.



A mechanical door coordinator is needed to ensure correct closing in double fire doors!

Note!

13 SELF DIAGNOSTICS

Fault codes

- detect malfunctions
- to ensure safe operation where possible during malfunction
- to restore the operator to its required status

If the door operator is unrecoverable it will revert to manual operation only.
Both LED's will blink.

Control units LED's

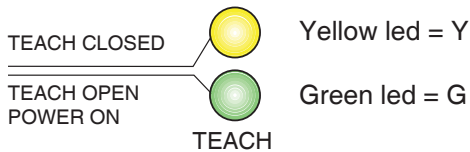

Indication	Possible fault	Corrective user interventions in defined order
G not lit Y not lit	No power. Faulty power supply unit. Faulty control board.	<ol style="list-style-type: none"> 1) Check the mains. 2) Disconnect 10 pin connector from the control board. 3) Measure the voltage of the power supply (7 pin connector, pins 1 and 3). If voltage is under 24VDC, change the power supply unit. 4) Measure the voltage from 10 pin connector (pins 9 and 10). If voltage is not 24VDC, change the control board.
G lit Y lit	The door "close" and "open" positions are not successfully taught. Impulse device is active all the time. Fire Detector is active.	<ol style="list-style-type: none"> 1) Teach the door open and close positions. 2) Check all impulse devices and connections. 3) Check fire detector connection and fire N.C. jumper.
G lit Y flash	Flash short...short...short...: 1000 ohm resistor is missing or cable of safety sensor is cut. Flash short...long...short...long...: Safety sensor is active or cable of safety sensor is short-circuited.	<ol style="list-style-type: none"> 1) Check that 1000 ohm resistor is connected in control board or in safety sensor. 2) Check that cables are not damaged. 1) Move obstacle from safety sensor detection area. If sensor sees the wall, adjust detection area. 2) Check that cables are not damaged.
G flash Y flash	Internal fault in the control board. Door motion is stopped.	<ol style="list-style-type: none"> 1) Switch main off for 10 seconds. 2) Check that all applicable jumpers are in place (one of two arms is selected, one door size is selected, "single" is selected). 3) Teach the door open and close positions. 4) Change the control board.
G flash Y flash alternates	Internal fault in the position sensor board. Door motion is stopped.	<ol style="list-style-type: none"> 1) Switch main off for 10 seconds. 2) Check that all applicable jumpers are in place (one of two arms is selected, one door size is selected, "single" is selected). 3) Check position sensors cable and connector. 4) Teach the door positions. 5) Change the position sensor.

14 MAINTENANCE

Door operators require periodic maintenance.

Only trained personnel are equipped to work on Abloy® DA products.

Door leaf is moving sensitively and locking works well.

Regular annual services are made:

- Under 100 openings per day; service once a year
- 100 ... 500 openings per day; service two times a year
- Over 500 openings per day; service 3...4 times a year

Inspections made in service:

- Fixing of the operator and arm
- Clearance of the clutch (see p.29)
- Function and adjustments of impulse and safety devices
- Programming and adjustments of the operator
- Movement of the door, taught door positions

14.1 Adjusting the clearance of the electromagnetic clutch

The clearance of the electromagnetic clutch has to be checked during regular service (see timescales on page 28). The clearance should be 0,3 mm. Re-adjust the clutch if needed.

Incorrect clearance causes, clutch drag or clutch slip, preventing the correct operation of the Abloy® door operator.

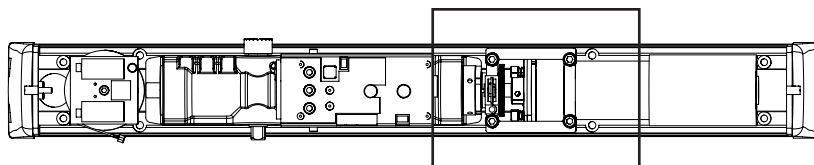

Remove the position sensor before adjusting the clutch (see p.14).
Loosen two holding screws.
Move the clutch plate with a screwdriver and mallet, if necessary.

Note! Do not insert any object between clutch plates, as damage may occur.

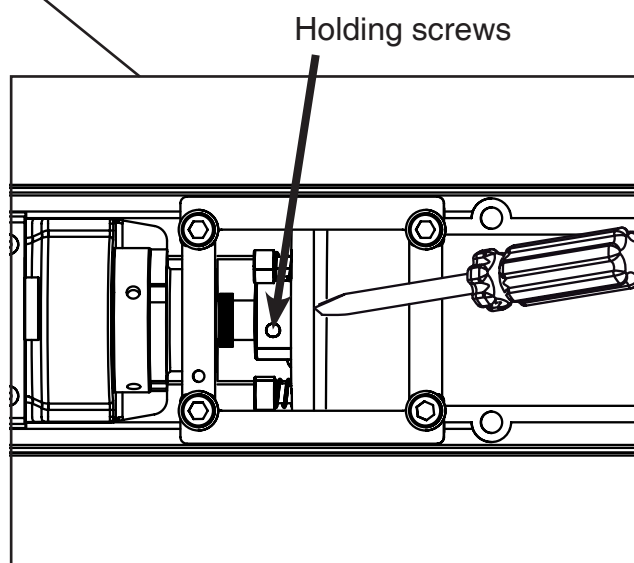

To adjust clearance of the clutch, use clearance gauge (0,3 mm).

Insert the gauge between the clutch plates and adjust the clearance by pushing the clutch from area showed in the drawing. Check that the clearance is equal in the whole clutch.
Note! Do not adjust the clearance by pushing from the clutch plate.

Tighten two holding screws. Re-install the position sensor.

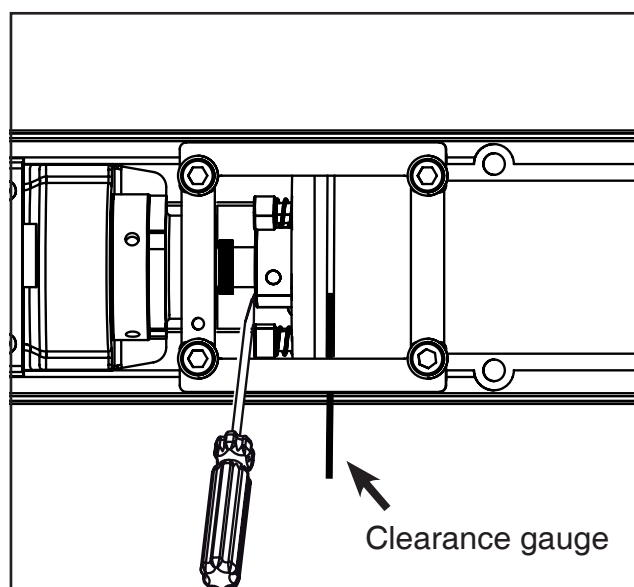

Do not grease the clutch!

15 SPARE PARTS

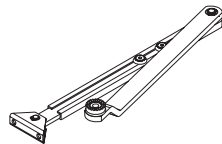
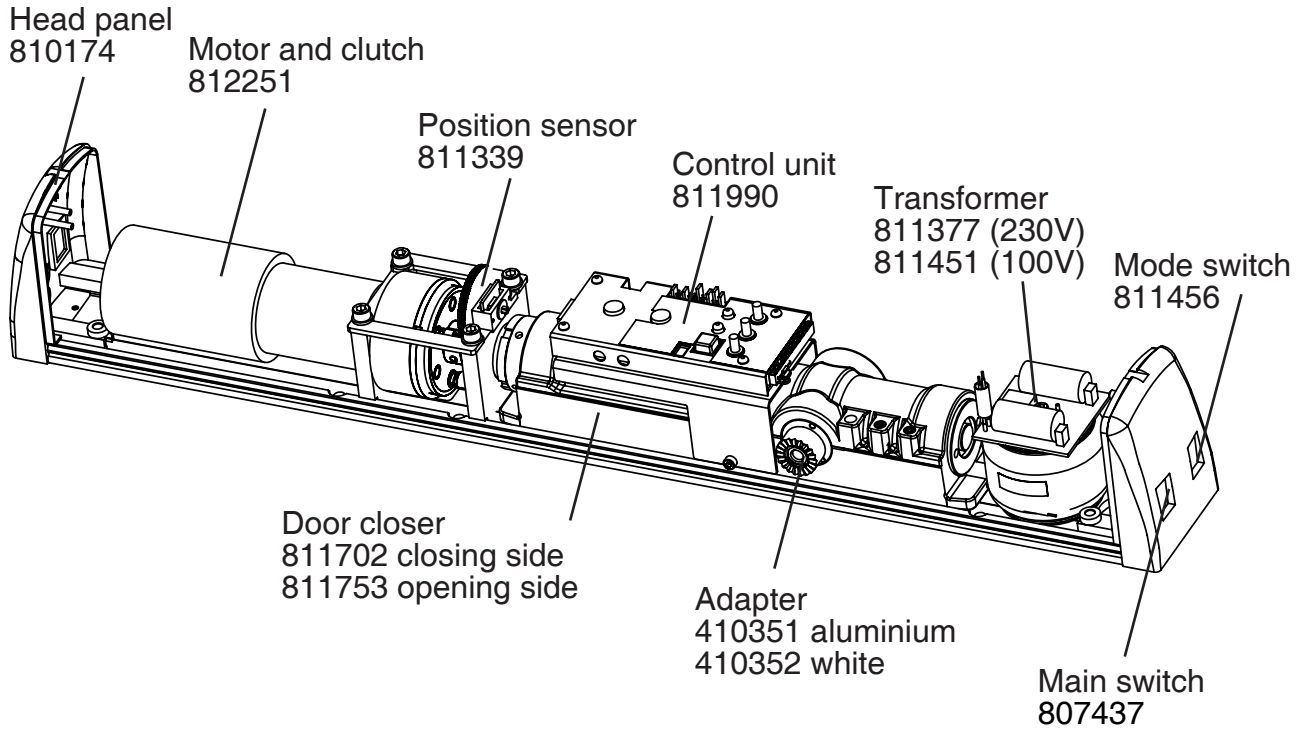

DA147/100000 A
DA147/600000 V
DA147/800000 E

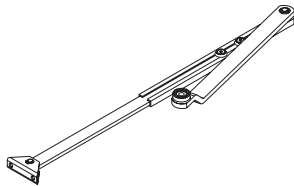

DA148/100000 A
DA148/600000 V
DA148/800000 E

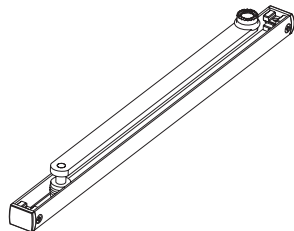

DA149/100000 A
DA149/600000 V
DA149/800000 E

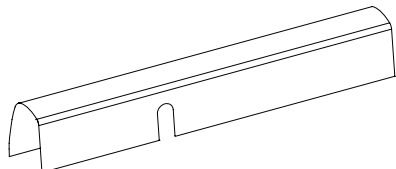

Cover
410365 aluminium
410364 white

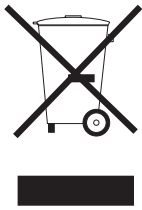

Some of the materials in this product, such as electronic components, require specialist recycling techniques.

Nimike
9312577
Päiväys
06/2008



Abloy Oy
Wahlforssinkatu 20
P.O. Box 108
FI-80101 JOENSUU
FINLAND
Tel. +358 20 599 2501
Fax +358 20 599 2209

www.abloy.com

